



# Practical peatland restoration

## Purpose

This Briefing Note aims to provide peatland managers with practical field guidance on peatland restoration. It states general guiding principles to be considered in all peatland restoration efforts and elaborates issues that only apply to specific restoration cases.

## Background

Resolution XIII.13: *Restoration of degraded peatlands to mitigate and adapt to climate change and enhance biodiversity and disaster risk reduction* requested the Scientific and Technical Review Panel (STRP) to consider, related to the fourth Strategic Plan 2016-2024, the further elaboration of practical experiences of restoration methods:

- for peatland types not yet covered by guidance of the Convention on Wetlands,
- based on the integrated approach to ecosystem restoration.

Based on this request, task 2.2. of the STRP work plan calls for the development of a Briefing Note on practical peatland restoration, building on Ramsar Briefing Note (No.4) *The benefits of wetland restoration* and Briefing Note (No. 10) *Wetland restoration for climate change resilience*. The task also calls for an associated Ramsar Technical Report (No. 11) *Global guidelines for peatland rewetting and restoration* (2021) and a Ramsar Policy Brief (No. 5) *Restoring drained peatlands: A necessary step to achieve global climate goals*.

This Briefing Note presents key information on practical peatland rewetting and restoration on site. It formulates general **guiding principles** applicable to all peatland restoration practices and provides detailed information on a wide range of **restoration techniques**, including peatland rewetting by building blocks, bunds and screens and by reducing leakage. It addresses relevant revegetation and vegetation management options, including peat swamp reforestation in the tropics and tree and shrub removal, revegetation and the re-installment of traditional management to restore open mire vegetation in the temperate and boreal zones.



## Relevant Ramsar documents

[Resolution XIII.13](#): Restoration of degraded peatlands to mitigate and adapt to climate change and enhance biodiversity and disaster risk reduction

[Resolution XII.11](#): Peatlands, climate change and wise use: Implications for the Ramsar Convention

[Resolution VIII.16](#): Principles and guidelines for wetland restoration

[Resolution XIII.12](#): Guidance on identifying peatlands as Wetlands of International Importance (Ramsar Sites) for global climate change regulation as an additional argument to existing Ramsar criteria

[Briefing Note No. 4](#): The benefits of wetland restoration

[Briefing Note No. 10](#): Wetland restoration for climate change resilience

## Key messages

- **The rewetting and restoration of degraded peatlands on a hitherto unprecedented scale is essential to achieve the UN Sustainable Development Goals (SDGs) and the goals of the Paris Agreement of the United Nations Framework Convention on Climate Change (UNFCCC).**
- **The most important restoration technique is rewetting, i.e., raising the annual average water table to around the peat surface.** This must be done by blocking drainage structures (ditches, canals, gullies) and – if this is insufficient to re-establish high and stable water levels – by building/ facilitating surface structures (bunds, hummocks, buttressed and stiltrooted trees) to slow down surficial water outflow to create a water buffer for dry seasons above the peat surface.
- **Blocks and bunds can be made from a range of materials and in various designs, depending on particular needs; use of local materials is generally cheaper.** This Briefing Note describes multiple options.
- **Re-establishing a suitable vegetation is vital for protecting the peat body, re-installing peat formation, supporting biodiversity and often also (i.e., in sphagnum raised bogs and tropical domed peat swamp forests) for restoring adequate hydrological conditions.**
- **Re-establishing a target vegetation may also require tree removal (i.e., in originally open mires) and nutrient removal in nutrient-enriched sites, e.g., by top soil removal or phytoextraction (cf. paludiculture).**
- **Revegetation may rely on spontaneous regeneration but may in many cases require re-introduction of plants, e.g., by hay, sod or moss transfer, seeding or planting.**
- **Restoration can only support but not fully control recovery.** In the end, nature itself must do the job. This will take time, often much time (decades or more).

## The issue

The rewetting and restoration of degraded peatlands on a hitherto unprecedented scale is essential to comply with the UN SDGs and the Paris Agreement. This will require clear and comprehensive technical guidance. Central to peatland restoration is rewetting, i.e., bringing the water table back to at or over the peat surface. Additionally, the re-establishment of peat-forming or peat-protecting vegetation is required to prevent further deterioration.

This Briefing Note summarizes the main guiding principles and field techniques of peatland rewetting and restoration on site. Together with the references and associated Ramsar Technical Report No. 11, *Ramsar global guidelines for peatland rewetting and restoration* it will guide peatland managers and practical decision makers to appropriate solutions for local restoration problems and conditions. Note that degradation caused by activities and developments outside peatland is not addressed in this document.

## Introduction

A significant part of the world's peatlands has been transformed and drained causing large environmental problems, including globally relevant greenhouse gas emissions. This has brought peatland restoration to the agenda of the Convention on Wetlands and many other national and international policy frameworks.

The necessary measures for peatland rewetting and restoration depend on the peatland type, on how strongly the peatland is degraded and on the final restoration aims. Information on peatland typology, restoration goal setting and further background considerations can be found in the Ramsar Technical Report No. 11 *Ramsar global guidelines for peatland rewetting and restoration*.

## Existing guidance

To find practical solutions for local problems, it is good to draw on existing information. Useful peatland restoration manuals are Kozulin *et al.* 2010 (Belarus), Stańko *et al.* 2018 (Poland, alkaline fens), Dinesen & Hahn, 2020 (Northern bogs), Similä *et al.* 2014 (Finland), Van Duinen *et al.* 2017 (Netherlands, bogs), Grosvernier & Staubli, 2009 (Switzerland), Mackin *et al.* 2017 (Ireland), Wheeler & Shaw, 1995, Thom *et al.* 2019, Ferré & Martin-Ortega, 2019 (United Kingdom), Giesen & Nirmala Sari 2018, the Indonesian Peatland Restoration Agency (<http://brg.go.id/panduan/>), Parish *et al.* 2019 (Tropics with focus on SE Asia), Landry & Rochefort, 2012 and Quinty & Rochefort, 2003 (Canada). This Briefing Note summarizes the major insights from these and other guidance documents.

## General guidance

Some guiding principles apply to all practical peatland restoration:

- Peat formation requires a rather narrow range of (high) water levels. Peat formation is hampered both by too low water levels (boosting peat oxidation) and too high water levels (reducing plant production, increasing water erosion).
- Peat soil wetness must be almost permanent because peat decomposes ten times faster when drained than the rate that it builds up when sufficiently wet.
- Peat is almost as light as water and, therefore, easily erodes if not protected. Restoration must, therefore, disperse water flow (not concentrate it!) and re-establish vegetation on bare peat surfaces. Furthermore, peat should be kept wet to prevent oxidation.
- Peat is soft, so that heavy machinery may easily sink away, necessitating adapted action and the employment of experienced workers.
- Water flows from high to low. To keep access, rewetting activities must start from the highest point and work successively downwards.
- Local materials (peat, wood, sods and sand) are generally cheaper and, therefore, often preferred for making blocks and bunds. The use of foreign materials (hardwood, plastics, metal and geotextiles) may, however, be necessary to construct durable and optimally performing devices.
- Any construction will over time deteriorate, be destroyed (e.g., when blocks frustrate local access) or its 'valuable' materials may be stolen. Blocking systems should therefore be constructed inherently robust by:
  - Reducing pressure and erosion risk for each block by building a cascade of blocks with limited water level differences (0.10-0.25 m).
  - Not allowing water to run over a block.
  - Infilling of ditches and canals (also partial) to allow them to be overgrown and filled in by vegetation, which reduces water steps over and pressure on the blocks.
- Let nature do the work: In the end, nature must restore itself – people can only help but not fully control.

More specialized guidance is presented in the following sections.



## Building blocks and bunds

High and stable water levels are crucial for peatlands. Therefore, the construction of *blocks* (dams to reduce/ stop water losses through ditches and canals) and *bunds* (dikes and embankments to reduce/ stop water losses over the surface) is central in peatland rewetting and restoration. General recommendations with respect to building both include:

- If possible, work under dry conditions, i.e., in the driest period of the year, or create locally drier conditions by constructing temporary dams up- and downstream and by pumping.
- Avoid working during frost when peat and clay are difficult to handle and have an unstable structure.
- Start damming at the most upstream part of the drainage system to reduce water pressure downstream (reducing risk of block failure) and to keep the area accessible as long as possible.
- The distance between dams should reflect the surface slope: larger spacing on gentle slopes and closer spacing on steeper slopes.
- Places less suitable for block locations include sites with large plant tussocks and trees (whose roots are difficult to cut through and may provide a conduit for water seepage), small depressions along the drain profile, and cracked, oxidised and eroded peat banks (where water may seep through).
- To aid future monitoring, record the location of all blocks using sub-metre accuracy Global Positioning System (GPS), and their basic dimensions (width, height, length).

## Materials

- Blocks and bunds do not have to be completely impermeable, but rather have a permeability comparable to that of the surrounding peat.
- Low humified peat (measured as Von Post H1-3 on the humification scale<sup>1</sup>) has a high hydraulic conductivity. Preferably use wet, more decomposed peat (Von Post H6 – H8) to build leak-proof blocks and bunds. Highly oxidised peat, e.g., scraped off peat or material excavated when the ditches were dug, may have lost its water retentive properties, and should be avoided for block building. This material can be used to fill the ditches.
- Wet peat is heavy and is best taken from the immediate vicinity upstream of the block or bund. If peat is removed from downstream of the block/ bund, scars remain more noticeable. Care should be taken that a string of excavation hollows will not act as a parallel drain.
- When constructing large dams of wood with peat, it may be necessary to add stones or cement to solidify the structure and counteract floatability.
- Use wood that does not easily rot. Minimize the risk of rotting by keeping the constructions submerged in water or covered by well-compacted peat.

## Block construction

- Vegetation should be cleared out where blocks are to be built, to ensure a good seal.
- To prevent erosion, the width of the block must exceed that of the drain/canal on both sides to make sure that the water does not flow around the block and return to the drain. Installing the block at an angle (i.e., not perpendicular) to the drain may discourage water from flowing round the block.
- Blocks must be big enough and compressed carefully to ensure they can withstand water pressure even during flood seasons. Blocks should be at least two metres long in the direction of the ditch.
- The top of the blocks should be higher than the surrounding ground level to compensate for shrinkage and to allow the impounded water to flow laterally away over the peatland surface.
- Blocks and bunds should finally be covered with vegetation, to keep them in place and to reduce the risk that they will be washed away by floods. Plastic plates (*see below*) must be covered to prevent degradation by UV light.

---

1 <https://www.blacklandcentre.org/the-science/von-post-humification-scale/>.

**Figure 1**  
Various blocks in restoration projects in Finland.

From left to right: 1. Block from tongue-and-groove boards in large or badly eroded ditches. 2-4 Log blocks constructed where suitable logs are easily available (e.g., from trees felled on the site). If the peat is deep, the logs can be sunk vertically into the peat. Where peat deposits are only shallow, the logs can be put in place horizontally. The block should then be covered with geotextile and peat. Log blocks can be stabilised with the help of supporting logs aligned at right angles to the other logs. 5. Blocks of plywood to block shallower ditches. Boards should be sawn to sizes with greater length and depth than the ditch. To put them in place grooves can be cut in the peat using a long-reach chainsaw. The boards can then be hammered into place e.g., with a sledgehammer. Peat should then be shovelled in between the boards and packed tightly. 6. Jute sacks filled with compressed peat for repairing blocks in restored sites where excavators can no longer work. Sacks can be fixed in place using wooden stakes hammered into the peat. The geotextile used to cover the boards is only partly shown to enable the underlying structures to be seen. (From Similä *et al.* 2014. Illustrations from Tupu Vuorinen).

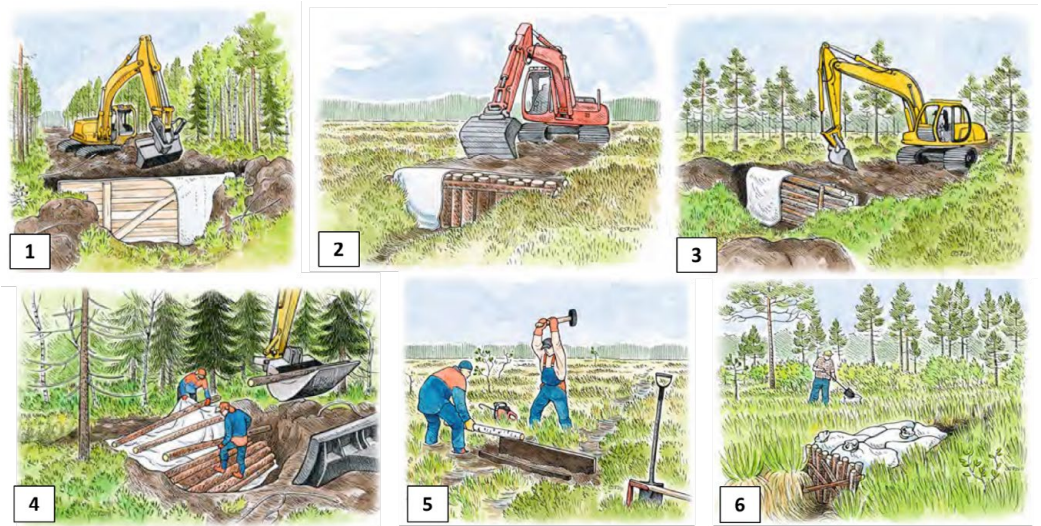

## Dam design

The following block types are fit for small ditches:

- **Peat blocks** of well compacted peat to be used where the slope and water pressure are low. The wider the block (in the direction of the ditch), the more stable it is. To assure compaction, an excavator should press each layer of peat added.
- **Blocks of wooden planks** (figure 2a) are affordable and efficient. The planks should be sunk at least 60 cm into the peat (and if possible, into the mineral soil) and should go at least 60 cm into each side of the ditch to avoid water leaking through the block. Well-compacted peat placed upstream and downstream from the plank should stabilize and cover the installation. Similar blocks can be made from metal panels, plexiglass or corrugated plastic.
- **Blocks with double panels** (figure 2b) are appropriate when the water level difference across the block is more than 50 cm. They are constructed by installing two perpendicular panels in the ditch 3 to 4 m from one another and filling the space between the panels with peat or sawdust.
- **Blocks from bales of straw and heather brass** can be used in small ditches. The bales are compacted and solidified with logs or other types of stakes inserted deeply into the bottom of the ditch.

To improve the seal of the block, a geotextile can be added.

**Figure 2**  
Block designs of (a) a single plank dam (front view) and (b) a composite plank dam (top view) (From Dohong *et al.* 2018).

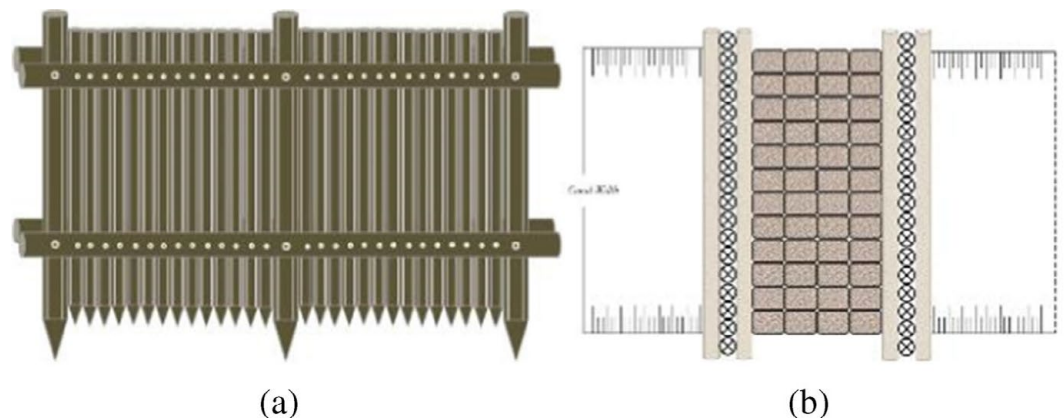

The following block types are fit for mid- and large-sized drains, ditches and canals:

- **Compacted peat blocks** are cheap, rapidly constructed and, when well-compressed, last at least ten years and often longer. However, they are easily damaged by persons wanting to re-open waterways.
- **Solid flow-around blocks** stop the draining effect of channels completely. The water in the channel rises to the level of the ambient surface and then bypasses the block in a broad front. Solid blocks are made from peat or other local soil material, possibly combined with wood. The width of the block on the top should be not less than 3 m for channels <4 m wide and 5 to 10 m for wider channels. For the side slopes a 30° angle to the bottom of the channel is recommended. The upper level of the dam after compacting should rise 0.7-1 m above the surrounding surface (at 10-20 m from the dam) of the peatland. The dams should extend to at least 3 m beyond the edge of channels, but in case of older, more subsided channels, all the way to the prevailing surface of the peatland. Places where water can only flow out in a narrow front should be reinforced to prevent erosion.
- **Blocks of wooden planks** consist of wooden tongue and groove planks piled horizontally or vertically and nailed together (figure 3 left). The planks must be inserted into the peat at the bottom of the ditch as deeply as possible and into the walls of the ditch (at least 60 cm) to assure solidity and avoid erosion. To assure impermeability, a geotextile or a polyethylene sheet can be installed at the upstream face of the planks. Well compacted peat up and downstream of the dam will cover and solidify the construction.
- **Double wooden blocks with backfilling** are used where water pressure is larger. These blocks consist of planks nailed and attached to U form structures for more stability.
- **Plastic piling blocks** are recommended for ditches that store much water, like in sloped peatlands or principal ditches into which secondary ditches flow. This type of block should be inserted as deeply as possible into the mineral soil to avoid leakage. The block can be doubled for more solidity.
- **Box or coffer blocks** consist of box-like structures usually made of wood and infilled with bags filled with sand or manually compacted peat. Box blocks are expensive, require lots of material that has to be brought in (timber, sandbags), take long to construct, last without maintenance only a brief time and are easily damaged.
- **Rock-filled blocks with piling wall** (figure 3 right) are used to regulate runoff by overflow in case of a high-water flow rate (more than 2 m<sup>3</sup>/s). In this block, a wooden wall is placed perpendicularly to the ditch and inserted very deeply. At each side of the block, a pile of peat is placed sloping away from the installation over 5 to 20 m and a layer of stones at least 20 cm thick added on top to prevent erosion. The dams should be constructed with no water in the watercourse, using temporary dams and water pumped out or a temporary bypass channel.
- **Water-discharge structures with concrete flumes** inserted in an earth block, which allow regulating water runoff in channels with high water flow rates (3-8 m<sup>3</sup>/s).
- **Stone gabions** are metal cages welded together, filled with stones and constructed in a ditch that reaches the mineral soil. It is not the stones that block the water flow, but the peat that settles and clogs the spaces between the stones. Gabions can be expensive if the material has to be transported onto the site.

**Figure 3**  
Overflow piling block made of planks (front view, left) and rock-filled block with piling wall (cross view, right) (From Kozulin *et al.* 2010).

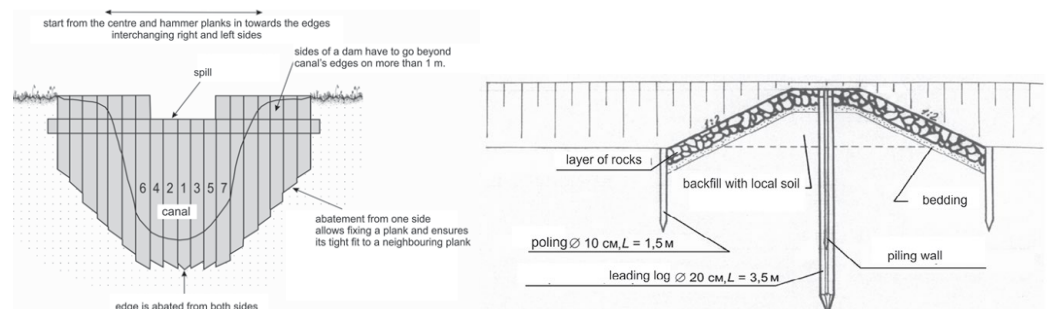

## Spillways and bypasses

Spillways and bypasses are constructions in or next to blocks that allow drainage of excess water or are installed to keep the area accessible (see Technical Report No. 11).

- If a spill-over construction must be installed in a block, care should be taken that the water backed up behind a block reaches the next upstream block well above its base to prevent falling water causing scouring of the drain base in front of the block. The difference in water levels upstream and downstream of the block should be limited to 20 to 30 cm to rewet a major part of the peatland.
- V-shaped notches allow increasingly more water to leave the area diffusely when water levels rise. Many small notches are in this respect more effective than a single large notch (figure 4).

**Figure 4**

To disperse water flow, several notches in a spillway are better than one single notch (front view, modified from Landry & Rochefort, 2012).



Whereas fixed bypasses (figure 5a) always lead to a suboptimal peatland water level, flexible flap weirs (figure 5b) are a simple way to reconcile the opposing interests between attaining the highest possible water levels and allowing continued accessibility.



**Figure 5a**  
Box block with large spillway, Sebangau NP, Central Kalimantan. Photo © Wim Giesen.



**Figure 5b**  
Flap weir (Klappstau) in NW Germany with a fully passable, flexible weir.

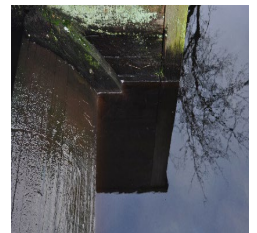

**Figure 5c**  
Detail of flap weir. Photo © Hans Joosten

## Backfilling

Backfilling (i.e., the completely filling of ditches/canals) is the most effective method to restore the water level of peatlands but requires much peat or other material. For backfilling (also known as *infilling*) the following considerations apply:

- Material used should be nutrient poor and impermeable. Dried, oxidised and mineralised peat is less suitable.
- As the peat is packed into the ditch, it should be compacted to decrease permeability. The volume needs to be greater than the volume of the ditch because of compression and loss of structure.
- Sawdust only needs to come to the level of the peatland as wet sawdust does not settle and does not need to be compacted. Sawdust mixed with wood chips can be interesting for eliminating logs of trees cut down during site preparation.
- At sufficiently short intervals, dams should be formed to ensure that water rises to the desired level.
- To prevent erosion, the surface should be covered with vegetation.

## Gullies

Gullies are erosional landforms created by running water, eroding sharply into the peat (and into the mineral subsoil beneath), typically on a hillside.

- The gully's head must be stabilised to prevent head-cutting and upward expansion.
- Like ditches, gullies can be blocked or filled. Revegetation (*see below*) will aid peat stabilisation.
- The height of gully blocks may remain lower than the surface of the adjacent peatland. This also means that the water table will not rise to the surrounding peat surface.
- Block spacing should be a function of gully slope and depth.
- For peat gullies, block widths should not exceed 4 m. For wider gullies wooden fencing, plastic piling and gabions are more effective.

## Bunds (berms, dikes) and screens

A bund is an elongated impermeable embankment or barrier. It may be used to restrict water loss or to impound open water. Types of bunds are (figure6):

- **Surface (or internal) bunds**, which increase water levels on over-steepened slopes. A bund may require the insertion of a plastic membrane to decrease its permeability if only slightly humified peat is available.
- **Wall (or peripheral) bunds**, which minimise lateral water loss at the edge of an isolated peatland remnant. Wall bunds must be strong enough to resist large water pressure. Wide bunds work better and should be reinforced or be wider at places where pressure is likely to be greater. Wall bunds may include a low permeability core/liner to limit water flowing through and underneath the bund. In steeply convex, or irregular, massifs it may be necessary to have two or more concentric bunds if wet conditions are to be maintained at the summit.
- **Parapet bunds** are used to raise the water level over the surface as a storage to limit annual water level fluctuations. Parapet bunds are most suited where the surface is flat, and peat prevents vertical water losses.
- **Bale bunds** of heather or straw bales or coir logs are applied to reduce erosion and waterflows across bare peat areas.

**Figure 6**  
The main types of bunds (From Wheeler & Shaw, 1995).

Surface bunds

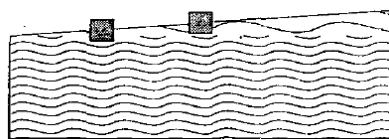



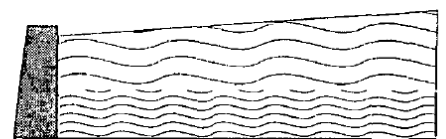

Wall bund



Parapet bund



-  weakly-humified peat
-  strongly-humified peat
-  open water
-  bund



For building surface and parapet bunds the following considerations apply:

- Surface peat and vegetation at the location of a bund has to be removed prior to building to provide better contact between bund and peat surface and limit the risk of leaking.
- Building bunds on slightly humified peat is less effective than on strongly humified peat because the former may cause leakage underneath the bund.
- Bunds can be made from strongly humified peat ('black peat'), whether or not in combination with a foil screen, a wooden sheet or impermeable mineral materials – often clay. The presence of wood, branches or other debris in the peat can weaken the bund and lead to leaking.
- The peat must be compacted thoroughly to ensure imperviousness and make it more resistant to water and wind erosion. The use of heavy machinery is recommended.
- The size and height of a bund depend on its purpose. A height of 40 to 50 cm after compaction usually provides sufficient surface water storage. Surface and parapet bunds must initially be built sufficiently high to allow for settlement (typically 20 to 25 cm).
- Bunds should be topped with turves to prevent desiccation and erosion.
- Wide bunds are more resistant to water pressure. Higher bunds freeze deeper than the surrounding area making them more resistant to water erosion in spring.
- To regulate water levels to prevent overflow erosion, devices that allow discharge of surplus water must be installed. The simplest and cheapest solution consists of a drainage pipe with a pivoting knee. A qualitatively better solution is an adjustable weir, which allows the level to be kept low in the early years and slowly raised as required.
- It is important to determine the correct height of the overflow. Large bodies of deep open water hamper vegetation re-colonisation and attract wild fowl and gulls, which cause nutrient-enrichment.
- The compartments must have a largely horizontal surface. The distance between the bunds must be such that the highest part of a compartment remains water saturated for most of the time, while the lowest part does not suffer from prolonged, deep inundation.
- Smaller compartments require a greater length of bunds but break up the area of standing water and prevent wave erosion from damaging the bunds.
- The re-wetting of the peat inside the bund will cause the peatland to rise, potentially altering gradients and water flow characteristics.
- Compartmentalisation must consider future developments. If the compartments should one day become a contiguous peatland, the compartments must be able to grow seamlessly together in terms of their mutual height differences.

## Screens

A foil screen within the soil or a bund can be used to prevent belowground water flowing out of a reserve, nutrient rich water flowing in from surrounding land, or groundwater flow between adjacent compartments with different levels.

- Polymer foil is delivered in long rolls. The foil should be installed in a continuous length to avoid the risk of leaks. The foil is typically run along the wall of a dug trench and backfilled with excavated soil. The foil may extend slightly above the soil surface within a soil bund.
- Screens may also be made of two layers of geotextile polypropylene fabric with bentonite granules in between. A bentonite screen may be used to make dikes waterproof.

## Reducing leakage

Sites where downward seepage is concentrated (e.g., ditches dug into the mineral subsoil) can be clogged by bringing in peat or other impermeable material (clay, bentonite).

## Revegetation and vegetation management

The approach to revegetate bare areas depends on the type of peatland, the state of degradation, and the plans for the area. If remnants of original vegetation remain, rewetting may be sufficient for the vegetation to regenerate. Revegetation of sloping bare peat may require the application of lime, fertilizer and a nurse crop (e.g., composed of amenity grasses) to provide initial ground cover.

## Reforestation of tropical peat swamp forests

The reforestation of tropical peat swamp forest is necessary to restore peatland hydrology (see Ramsar Technical Report No.11).

- Unassisted forest regeneration depends on the availability of seed dispersal agents (wind and small- to medium-sized birds) and on sprouting from vegetative remnants. Natural regeneration is probably achievable in the absence of fire, but will be slow with initially a low species diversity.
- If natural regeneration is insufficient, enrichment planting can assist recovery. Species selected should have a broad ecological tolerance (pioneer species) and be able to cope with exposure to direct sunlight, desiccation in dry months, and some degree of flooding in the wet season (see Ramsar Technical Report No. 11 for more details and species).
- Seedlings must be collected from the wild or from tree nurseries. Local seed provenance should be prioritized. Planting density could vary from 400 to 2,500 seedlings per ha ( $5 \times 5$  m or  $2 \times 2$  m, respectively). Higher stocking is recommended for slower growing species and/or poorer sites, for instance to avoid extra weeding.
- One month after planting, seedlings should be checked and any that have died be replaced. Weeding should continue until seedlings rise above the height of ferns and sedges (about 1.5 to 2 m); this is also the case for natural regeneration.
- If pioneer species are well established, shade tolerant or shade requiring species can be planted to speed up succession towards a mature mixed peat swamp. Beneficial timber and non-timber forest product) species should be utilised near villages or when restoration areas belong to a particular community.
- Detailed guidance on replanting is given in Nuyim, 2005, Giesen & van der Meer, 2009, Mahyudi *et al.* 2014, Wibisono & Dohong, 2017 and Parish *et al.* 2019.

## Forest, tree and shrub removal

Some peatlands naturally support tree-cover. However, in many cases the presence of trees is due to planting, invasion or expansion of trees following drainage of originally treeless or sparsely wooded peatlands. Peatland restoration may then involve the removal of trees.

- Rewetting is the most efficient way to remove or suppress tree and shrub growth in originally open mires. Additionally, tree/ shrub removal can be considered.
- Hand pulling is an effective method to remove small seedlings but disturbs the ground, which may then be seeded by neighbouring trees.
- Brush cutters and chainsaws can be used to clear established scrub manually. Both may cut into the peat without getting damaged.
- Regrowth often occurs from dormant buds below or just above the soil surface. It is therefore important to cut the tree below the surface to reduce regrowth.
- Some species coppice when cut and require secondary treatments such as cyclical cutting, ring barking, grazing or flooding. Ring barking will kill off the tree above the ring and may suppress resprouting more effectively than felling.
- The use of herbicides should be avoided. Herbicides should only be used if necessary, e.g., to control invasive species. Herbicides can be applied directly to the leaves, applied to the trunk or painted onto the cut stump. Their use should be carefully controlled both for health and safety reasons and so as not to affect non-target species.
- In forestry plantations, the plough throws and ditches should be evened to bring more ground surface in contact with the water table.
- Woody material should be removed from the site. Leaving the brush on site can lead to localised enrichment, shading out of intolerant species and enhanced fire risk.

When removal is impossible, the material may be spread, mulched, or used the backfill ditches or human-made open water bodies.

- Disposal of woody material by on site burning requires an emergency plan, optimal weather conditions (wet, not windy), a raised burning bin underlain by fire blankets or corrugated sheeting (to avoid contact with the peat soil), spades and beaters (in case the fire gets out of control), and the removal of the ash (as a concentrated fertiliser).

## Restoration of nutrient enriched sites

About half of the degraded peatland area worldwide is formed by peatlands in agricultural use and partly, often heavily, nutrient enriched. For these lands three options exist with respect to rewetting and restoration: topsoil removal, phytoextraction (*cf.* paludiculture, or wet agriculture and forestry on peatlands) or accepting that hypertrophic fens with low biodiversity will persist for decades or longer.

- Prescreening of depth profiles for biologically available phosphorous can show whether topsoil removal may be useful, and to what depth.
- The removed soil can be used for filling material nearby ditches.
- Chemical alternatives to lower phosphorous availability, such as the addition of iron, calcium or lanthanum-modified clay, have been shown to fail (Geurts *et al.* 2011).

In case the desired species do not establish spontaneously, re-introduction can be considered.

- Hay transfer involves mowing a donor fen site, when the desired seeds are ripe yet still attached to the stalks, and transferring the 'hay' directly onto the restoration site. Several harvests through the season allow the inclusion of species with different flowering times.
- For those species that do not readily produce viable seed, the transfer of small (30 cm x 30 cm) turfs (with sufficient depth to include the rhizomes!) will help accelerate the re-establishment of fen species. Transplantation is best undertaken at the beginning of the growing season.
- In the case of planting, herbivory by geese and other wetland birds can be addressed using netting or repelling devices.
- The Moss Layer Transfer Technique implies the active reintroduction of peatland plant species, especially peatmosses, combined with rewetting. The method involves: preparing the sector to be restored, collecting plant material from a donor site, spreading the plant material, spreading mulch as a protective cover, fertilizing, rewetting by blocking the drainage system, and monitoring the restored sectors. The method is extensively described in Quinty & Rochefort, 2003 with enlarged chapters published in 2019 and 2020.
- A nurse crop is useful in sites with large expanses of bare peat, helps to stabilize the peat and provides shelter to newly establishing mosses. Nursery plants for bogs may include *Eriophorum*, *Carex* and *Polytrichum strictum*.

## Restoring traditional management

Traditionally, many naturally open fens in Europe and Eastern-Asia were mown and grazed for fodder and litter (and often slightly drained). After use was abandoned, these fens suffered heavy losses in typical species diversity, a decrease in bryophyte cover, a dominance of some graminoid species, and tree and shrub encroachment.

The former vegetation can be restored through intensive mowing. This may, however, also lead by the destruction of microtopography, to a loss of fen specialists, bird nests and red listed species, and enhanced acidification. Preference should therefore be given to restoring pre-exploitation hydrologic conditions, if still possible (*see* Ramsar Technical Report No. 11).

***For further guidance, consult the references below and Ramsar Technical Report No. 11.***

## Author

Joosten, H., Greifswald University and Duene e.V., Partners in the Greifswald Mire Centre, Greifswald, Germany.

## Citation

Convention on Wetlands. (2021). *Practical peatland restoration*. Briefing Note No. 11. Gland, Switzerland: Secretariat of the Convention on Wetlands.

## Acknowledgement

The development of Briefing Note No. 11 was made possible with financial support from the Norwegian Ministry of Climate and Environment

## Note

This version of Briefing Note No. 11 was amended on 19.11.2021

## References

- Blackham, G.V., Webb, E.L. & Corlett, R.T. (2014). Natural regeneration in a degraded tropical peatland, Central Kalimantan, Indonesia: implications for forest restoration. *Forest Ecology and Management*, 324, 8–15. <https://www.sciencedirect.com/science/article/abs/pii/S0378112714001959>.
- Dinesen, L. & Hahn, P. (2019). Draft Ramsar Technical Report on peatland restoration and rewetting methodologies in Northern bogs. STRP22 Doc.7.2. <https://www.ramsar.org/document/strp22-doc72-draft-ramsar-technical-report-on-peatland-restoration-and-rewetting>.
- Dohong, A., Aziz, A.A. & Dargusch, P. (2019). A review of techniques for effective tropical peatland restoration. *Wetlands*, 38, 275–292. <https://link.springer.com/content/pdf/10.1007/s13157-018-1017-6.pdf>.
- Ferré, M. & Martín-Ortega, J. (2019). A User Guide for Valuing the Benefits of Peatland Restoration. An iCASP (integrated Catchment Solutions Programme) report developed in collaboration with Yorkshire Peat Partnership and Moors for the Future Partnership. 49 pp. <https://icasp.org.uk/resources/peat-resources/user-guide-for-valuing-the-benefits-of-peatland-restoration/>.
- Geurts, J.J.M., van de Wouw, P.A.G., Smolders, A.J.P., Roelofs, J.G.M. & Lamers, L.P.M. (2011). Ecological restoration on former agricultural soils: feasibility of in situ phosphate fixation as an alternative to top soil removal. *Ecological Engineering*, 37, 1620–1629. <https://www.sciencedirect.com/science/article/pii/S0925857411002278/pdf>.
- Giesen, W. & Nirmala Sari, E.N. (2018). Tropical peatland restoration report: The Indonesian case. *Berbak Green Prosperity Partnership/Kemitraan Kesejahteraan Hijau (Kehijau Berbak)*. Jakarta, Indonesia: Euroconsult Mott MacDonald Graha CIMB Niaga 82 pp. [https://www.researchgate.net/publication/323676663\\_Tropical\\_Peatland\\_Restoration\\_Report\\_the\\_Indonesian\\_case](https://www.researchgate.net/publication/323676663_Tropical_Peatland_Restoration_Report_the_Indonesian_case).
- Giesen, W. & van der Meer, P.J. (2009). Guidelines for the rehabilitation of degraded peat swamp forests in Central Kalimantan (first draft). Project report for Master Plan for the Conservation and Development of the Ex-Mega Rice Project Area in Central Kalimantan. Jakarta, Indonesia: Euroconsult Mott MacDermott, 66 p. <https://edepot.wur.nl/175467>.
- Graham, L.L.B., Giesen, W. & Page, S.E. (2017). A common-sense approach to tropical peat swamp forest restoration in Southeast Asia. *Restoration Ecology*, 25, 312–321. <https://onlinelibrary.wiley.com/doi/abs/10.1111/rec.12465>.
- Grosvernier, P. & Staubli, P. (2009). Régénération des hauts-marais, bases et mesures techniques. L'environnement pratique n°0918. Berne: Office fédéral de l'environnement, 96 pp. [https://www.bafu.admin.ch/dam/bafu/fr/dokumente/schutzgebiete/uv-umwelt-vollzug/regeneration\\_vonhochmooren.pdf.download.pdf/regeneration\\_deshauts-marais.pdf](https://www.bafu.admin.ch/dam/bafu/fr/dokumente/schutzgebiete/uv-umwelt-vollzug/regeneration_vonhochmooren.pdf.download.pdf/regeneration_deshauts-marais.pdf).
- German version: [https://www.bafu.admin.ch/dam/bafu/de/dokumente/schutzgebiete/uv-umwelt-vollzug/regeneration\\_vonhochmooren.pdf.download.pdf/regeneration\\_vonhochmooren.pdf](https://www.bafu.admin.ch/dam/bafu/de/dokumente/schutzgebiete/uv-umwelt-vollzug/regeneration_vonhochmooren.pdf.download.pdf/regeneration_vonhochmooren.pdf).
- Kozulin, A.V., Tanovitskaya, N.I. & Vershitskaya, I.N. (2010). Methodical recommendations for ecological rehabilitation of damaged mires and prevention of disturbances to the hydrological regime of mire ecosystems in the process of drainage. Belarus: Scientific and Practical Center for Bio Resources - Institute for Nature Management of the National Academy of Sciences of Belarus 39 pp. [http://content-ext.undp.org/aplavs\\_publications/2944594/Belarus\\_guidebook\\_%20peatland\\_restoration.pdf](http://content-ext.undp.org/aplavs_publications/2944594/Belarus_guidebook_%20peatland_restoration.pdf).
- Landry, J. & Rochefort, L. (2012). The drainage of peatlands – Impacts and rewetting techniques. Quebec, Canada: Peatland Ecology Research Group, Département de phytologie, Université Laval, 53 pp. [http://www.gret-perg.ulaval.ca/no\\_cache/en/pergs-publications/?tx-centrerecherche\\_pi1\[showUid\]=5985](http://www.gret-perg.ulaval.ca/no_cache/en/pergs-publications/?tx-centrerecherche_pi1[showUid]=5985).
- Mahyudi, A., Al-Zaqie, I. & Reforestasi, T. (2014). Tree planting guide: reforestation programme. Technical Report Jakarta: Kalimantan Forest and Climate Partnership, 32 pp. [http://www.forda-mof.org/index.php/download/attach/19\\_Tree\\_Planting\\_Guide\\_Reforestation\\_Programme1.pdf/3242](http://www.forda-mof.org/index.php/download/attach/19_Tree_Planting_Guide_Reforestation_Programme1.pdf/3242).
- Mackin, F., Barr, A., Rath, P., Eakin, M., Ryan, J., Jeffrey, R. & Fernandez Valverde, F. (2017). Best practice in raised bog restoration in Ireland. *Irish Wildlife Manuals*, No. 99. Ireland: National Parks and Wildlife Service, Department of Culture, Heritage and the Gaeltacht 82 pp. [https://www.npws.ie/sites/default/files/publications/pdf/IWM99\\_RB\\_Restoration\\_Best%20Practice%20Guidance.pdf](https://www.npws.ie/sites/default/files/publications/pdf/IWM99_RB_Restoration_Best%20Practice%20Guidance.pdf).
- Nuyim, T. (2005). Guideline on peat swamp forest rehabilitation and planting in Thailand. Thailand: Global Environment Centre & Wetlands International – Thailand Office, 97 pp. [http://www.gec.org.my/view\\_file.cfm?fileid=2898](http://www.gec.org.my/view_file.cfm?fileid=2898).
- Parish, F., Yan, L.S., Zainuddin, M.F. & Giesen, W. (eds.). (2019). Roundtable on Sustainable Palm Oil (RSPO): Manual on Best Management Practices (BMPs) for management and rehabilitation of peatlands, 2nd edition. Kuala Lumpur, Malaysia: RSPO, 178 pp. [http://www.gec.org.my/view\\_file.cfm?fileid=3458](http://www.gec.org.my/view_file.cfm?fileid=3458).
- Quinly, F. & Rochefort, L. (2003). Peatland restoration guide, second edition. Québec, Canada: Sphagnum Peat Moss Association and New Brunswick Department of Natural Resources and Energy, 106 pp. [http://www.gret-perg.ulaval.ca/no\\_cache/en/pergs-publications/?tx-centrerecherche\\_pi1\[showUid\]=6192](http://www.gret-perg.ulaval.ca/no_cache/en/pergs-publications/?tx-centrerecherche_pi1[showUid]=6192). In 2019 and 2020, chapter 4 was revised and republished in independent booklets:
- *Planning Restoration Projects* (replaces p. 13 to 24 in the 2003 Guide)
- *Site Preparation and Rewetting* (replaces p. 25 to 35 and p. 60 to 62)
- *Plant Material Collecting and Donor Site Management* (replaces p. 36 to 45)
- *Spreading of Plant Material, Mulch and Fertilizer* (replaces p. 46 to 59)
- Similä, M., Aapala, K. & Penttinen, J. (eds.). (2014). Ecological restoration in drained peatlands - best practices from Finland. *Vantaa: Metsähallitus*, 84 pp. <https://julkaisut.metsa.fi/julkaisut/show/1733>.
- Stańko, R., Wolejko, L. & Pawlaczek, P. (eds.). (2018). A Guidebook on Good Practices of alkaline fen conservation. Świebodzin, Poland: Klub Przyrodników Publishing House, 170 pp. [http://alkfens.kp.org.pl/wp-content/uploads/2018/11/GUIDEBOOK\\_EN.pdf](http://alkfens.kp.org.pl/wp-content/uploads/2018/11/GUIDEBOOK_EN.pdf).
- Thom, T., Hanlon, A., Lindsay, R., Richards, J., Stoneman, R. & Brooks, S. (2019). Conserving bogs: The management handbook, 2nd edition. <https://www.iucn-uk-peatlandprogramme.org/sites/default/files/header-images/Resources/Conserving%20Bogs%20The%20Management%20Handbook%202nd%20Edition.pdf>.
- Van Duinen, G.-J., von Asmuth, J., van Loon, A., van der Schaaf, S. & Tomassen, H. (2017). Duurzaam herstel van hoogveenlandschappen. Kennis, praktijkervaring en kennisleemten bij de inrichting van hoogveenkernen, randzones en bufferzones. Driebergen, Netherlands: Vereniging van Bos- en 301 pp. [https://www.natuurkennis.nl/Uploaded\\_files/Publicaties/obn212-nz-duurzaam-herstel-hoogveenlandschappen.56d5db.pdf](https://www.natuurkennis.nl/Uploaded_files/Publicaties/obn212-nz-duurzaam-herstel-hoogveenlandschappen.56d5db.pdf).
- Wheeler, B.D., & Shaw, S.C. (1995). Restoration of Damaged Peatlands – with Particular Reference to Lowland Raised Bogs Affected by Peat Extraction. London, U.K.: HMSO.
- Wibisono, I.T.C. & Dohong, A. (2017). Technical guidance for peatland revegetation. Jakarta, Indonesia: Peatland Restoration Agency (BRG) of the Republic of Indonesia, 85 pp. <http://brg.go.id/download/3413/>.

The views and designations expressed in this publication are those of its authors and do not necessarily represent the views of parties to the Convention on Wetlands or its Secretariat.

Reproduction of this document in whole or in part and in any form for educational or non-profit purposes may be made without special permission from the copyright holders, provided acknowledgment of the source is made. The Secretariat would appreciate receiving a copy of any publication or material that uses this document as a source.

Except where otherwise noted, this work is protected under a Creative Commons Attribution Noncommercial-No Derivative Works License.



Ramsar Briefing Notes are published by the Secretariat of the Convention on Wetlands in English, French and Spanish (the official languages of the Convention) in electronic format, and also in printed form when required.

Ramsar Briefing Notes can be downloaded from: <https://www.ramsar.org/resources/the-briefing-notes>.

Information about the Scientific and Technical Review Panel can be found at: [www.ramsar.org/about/the-scientific-technical-review-panel](http://www.ramsar.org/about/the-scientific-technical-review-panel).

For more information about Ramsar Briefing Notes or to request information on how to correspond with their authors, please contact the Secretariat of the Convention on Wetlands at: [strp@ramsar.org](mailto:strp@ramsar.org).

Published by the Secretariat of the Convention on Wetlands.

© 2021 Secretariat of the Convention on Wetlands.

## The Convention on Wetlands



The Convention on Wetlands, also known as the Ramsar Convention, is a global inter-governmental treaty that provides the framework for national action and international cooperation for the conservation and wise use of wetlands and their resources.